

Frybratt | Small Tilting Bratt Pans

The multi-function FRYBRAT bratt pan is a professional device able to cook, braise and fry medium or small amounts of food in a short time. This versatile cooking system with compact dimensions, includes the possibility of countertop installation and is really easy to use, so much so that it is seen as an indispensable tool in every kind of environment.

Multipurpose equipment for a truly professional kitchen

Thanks to the power used and the temperatures that can be reached by this equipment, Frybratt can also work as a fry-top serving, if necessary, as a valuable aid in the handling of extraordinary workloads.

DIRECT ELECTRIC HEATING NON PRESSURISED

MODEL	CAPACITY lt	POWER kW	DIMENSIONS mm	SURFACE dmq	NOTES
CBRE 40	40	6	800 x 670 x 530H	29	3N + PE AC 400V 50 Hz



Frybratt can be used for

- Broths
- Rice
- Pasta
- Fish
- Vegetables
- Meat balls
- Omelette
- Mirepoix
- Pastries

boiling | **braising** | pasteurising | **tilting** | **mixing** | cooling | frying | underpressure | vacuum cooking | cutting | washing | drying

TECHNICAL DRAWING MOD. **CBRE 40**

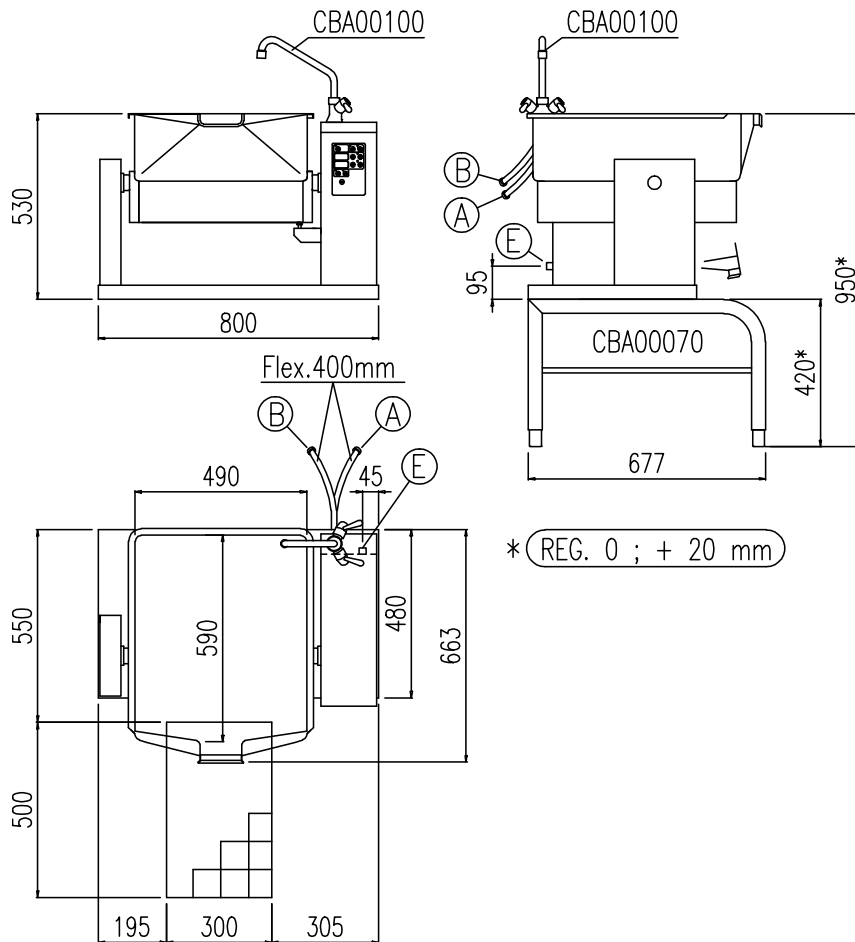

E	Potenza assorbita Electric power	Elektrische Leistung Puissance électrique	6.00 (kW)
E	Collegamento Elettrico Electric connection	Elektrische Verbindung Connexion électrique	380-415V 3N ~ 50/60Hz

Optional : CBA00100

A	Allacciamento Acqua Calda Hot water inlet	Warmwasseranschluss Raccordement eau chaude	1/2"
B	Allacciamento Acqua Fredda Cold water inlet	Kaltwasseranschluss Raccordement eau froide	1/2"